

# ***Shark***

## **Clean & Empty PowerDetect Speed Cordless Vacuum**

IA3000 Series

### **OWNER'S GUIDE**

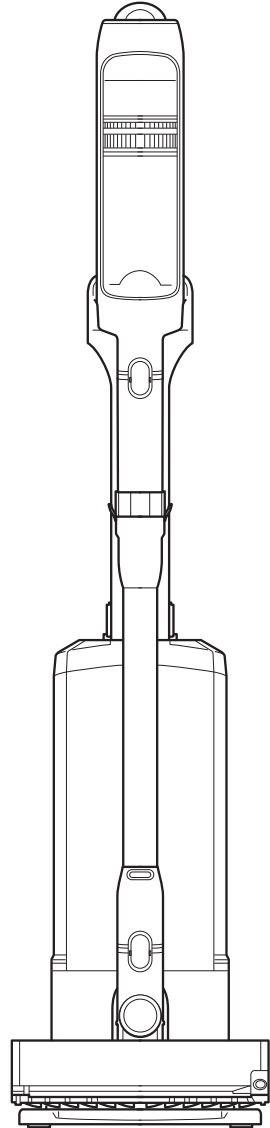

# THANK YOU

for purchasing the Shark PowerDetect Speed Cordless Vacuum.



**TIP:** You can find the model and serial numbers on the QR code label located underneath the battery on your unit.

**TIP:** You can locate the date code on one of the prongs of the power cord plug.

## ANTI-ODOUR TECHNOLOGY



### DANGER

**If in direct contact with contents of cartridge:**  
May cause an allergic reaction to skin.

Wear protective gloves if directly coming into the contact with the cartridge. Wash skin thoroughly after handling. Harmful if swallowed. Avoid breathing in mist or vapours, intentional misuse and directly inhaling contents may be dangerous. Avoid release to the environment. Very toxic to aquatic life with long lasting effects, ensure cartridge is disposed of correctly as general waste.

**2-(4-tert-butylbenzyl) propionaldehyde**  
May damage fertility and suspected of damaging the unborn child. Do not handle until all safety precautions have been read and understood. Use personal protective equipment, such as protective gloves, as required.

## REGISTER YOUR PURCHASE

**TO BENEFIT FROM YOUR PRODUCT'S EXTENDED GUARANTEE, SIMPLY REGISTER YOUR PURCHASE AT:**

 [sharkclean.co.uk/register-guarantee](http://sharkclean.co.uk/register-guarantee)

 +44 (0)800 862 0453

 Scan QR code using mobile device

Please note, products purchased directly from Shark are automatically registered.

Benefits of registering your product and creating an account:

- Get easier, faster product support and access to guarantee information
- Access troubleshooting and product care instructions
- Be among the first to know about exclusive product promotions

## RECORD THIS INFORMATION

Model Number: \_\_\_\_\_

Serial Number: \_\_\_\_\_

Date Code: \_\_\_\_\_

Date of Purchase (Keep Receipt): \_\_\_\_\_

Store of Purchase: \_\_\_\_\_

## TECHNICAL SPECIFICATIONS

Voltage: 18V

Body Motor Watts: 350W

Nozzle Watts: 115W

Off Mode Power Consumption: 0.4W

## PLEASE READ CAREFULLY AND KEEP FOR FUTURE REFERENCE.

This instruction manual is designed to help you get a complete understanding of your new Shark Power Detect Cordless Vacuum.

If you have any questions, please call the customer service line on +44 (0)800 862 0453.

# CONTENTS

<b>Product Registration</b> .....	<b>2</b>
<b>Important Safety Instructions</b> .....	<b>4</b>
<b>Assembling your Shark Power Detect Vacuum Cleaner</b> .....	<b>6</b>
<b>Using Your Anti-Odour Technology (IA3000 Series Only)</b> .....	<b>8</b>
Adjusting the Anti-Odour Technology Intensity .....	8
Odour Cartridge Replacement .....	9
<b>Charging Your LI-ION Battery</b> .....	<b>10</b>
<b>Using Your Vacuum</b> .....	<b>12</b>
Controls And Cleaning Modes .....	12
Detect Technology Explained .....	13
Flexology and Storage .....	14
Above-Floor Cleaning .....	15
Using the Auto-Empty Dock .....	16
<b>Maintaining your Vacuum Cleaner</b> .....	<b>17</b>
Emptying The Dock Dust Bin (IA3000 Series Only) .....	17
Filter Cleaning .....	18
Nozzle Maintenance .....	20
Cleaning The Sensors .....	21
Checking For Blockages In The Vacuum .....	22
Checking For Blockages In The Auto Empty Dock (IA3000 Series Only) .....	22
<b>Troubleshooting</b> .....	<b>23</b>
<b>Additional Accessories Available</b> .....	<b>24</b>
<b>Manufacturer's Guarantee</b> .....	<b>25</b>
<b>Notes</b> .....	<b>26</b>



This marking indicates that this product should not be disposed with other household wastes. To prevent possible harm to the environment or human health from uncontrolled waste disposal, recycle it responsibly to promote the sustainable reuse of material sources. To return your used device, please use the return and collection systems or contact the retailer where this product was purchased. They can take this product for environmentally safe recycling.



# IMPORTANT SAFETY INSTRUCTIONS

FOR HOUSEHOLD USE ONLY • PLEASE READ ALL INSTRUCTIONS BEFORE USING THIS VACUUM.

To reduce the risk of shock and unintended operation, turn off power and remove the ION Power Pack battery before servicing.

**NOTE: If you have delicate or wool carpets, particularly loop pile, please try the vacuum on a hidden area first to ensure the spinning brush-rolls do not damage or unpick carpet fibres.**



## ⚠ WARNING

REDUCE THE RISK OF FIRE, ELECTRIC SHOCK, INJURY, OR PROPERTY DAMAGE:

- This vacuum consists of a motorised nozzle, wand, and handheld vacuum. These components contain electrical connections, electrical wiring, and moving parts that potentially present risk to the user.
  - Before each use, carefully inspect all parts for any damage. If a part is damaged, discontinue use.
  - Use only identical replacement parts.
  - This vacuum contains no serviceable parts.
  - Use only as described in this manual. **DO NOT** use the vacuum for any purpose other than those described in this manual.
  - With the exception of the filters and dust cup, **DO NOT** expose any parts of the vacuum to water or other liquids.
  - DO NOT** allow the appliance to be used by children. Keep the appliance and its cord out of reach of children. Do not allow to be used as a toy. Close supervision is necessary when used near children.
- ### GENERAL USE
- This appliance can be used by persons with reduced physical, sensory or mental capabilities or lack of experience and knowledge if they have been given supervision or instruction concerning use of the appliance in a safe way and understand the hazards involved. Cleaning and user maintenance should not be done by children.
  - Always turn off the vacuum before connecting or disconnecting any current carrying hoses, motorised nozzles, chargers, batteries, or other electrical or mechanical parts.
  - DO NOT** handle plug or vacuum with wet hands.
  - DO NOT** use without dust cup, filters, and brush-roll in place.
  - Only use Shark branded filters and accessories. Damage caused by non-Shark filters and accessories may not be covered by the guarantee.
  - DO NOT** put any objects into nozzle or accessory openings. **DO NOT** use with any opening blocked; keep free of dust, lint, hair, and anything that may reduce airflow.
  - DO NOT** use if nozzle or accessory airflow is restricted. If the air paths or the motorised floor nozzle become blocked, turn the vacuum off. Remove all obstructions before you turn on the unit again.
  - Keep nozzle and all vacuum openings away from hair, face, fingers, uncovered feet, or loose clothing.
  - DO NOT** use if vacuum is not working as it should, or has been dropped, damaged, left outdoors, or dropped into water.
  - Use extra care when cleaning on stairs.
  - DO NOT** leave the vacuum unattended while powered on.
  - When powered on, keep the vacuum moving over the carpet surface at all times to avoid damaging the carpet fibres.
  - If you have delicate or wool carpets, particularly loop pile, please try the vacuum on a hidden area first to ensure the spinning brush-rolls do not damage or unpick carpet fibres.
  - DO NOT** use to pick up:
    - Liquids
    - Large objects
    - Hard or sharp objects (glass, nails, screws, or coins)
    - Large quantities of dust (including drywall, fireplace ash, or embers). **DO NOT** use as an attachment to power tools for dust collection.
    - Smoking or burning objects (hot coals, cigarette butts, or matches)
    - Flammable or combustible materials (lighter fluid, petrol, or kerosene)
    - Toxic materials (chlorine bleach, ammonia, or drain cleaner)

- DO NOT** use in the following areas:
  - Wet or damp surfaces
  - Outdoor areas
  - Spaces that are enclosed and may contain explosive or toxic fumes or vapours (lighter fluid, petrol, kerosene, paint, paint thinners, mothproofing substances, or flammable dust)
- Turn off the vacuum before plugging in or unplugging the charger.
- Turn off the vacuum before any adjustment, cleaning, maintenance or troubleshooting.
- During cleaning or routine maintenance, **DO NOT** cut anything other than hair, fibres, or string wrapped around the brush-roll.
- Allow all filters to air-dry completely before replacing in the vacuum to prevent liquid from being drawn into electric parts.
- DO NOT** modify or attempt to repair the vacuum or the battery yourself, except as indicated in this manual. **DO NOT** use the battery or vacuum if it has been modified or damaged. Damaged or modified batteries may exhibit unpredictable behavior resulting in fire, explosion or risk of injury.
- Turn off all controls before unplugging.
- Always turn off this appliance before connecting or disconnecting motorised nozzle or hand tool.
- If the supply cord is damaged, it must be replaced by the manufacturer, its service agent or similarly qualified persons in order to avoid a hazard.

### BATTERY PACK

- The battery is the power source for the vacuum. Carefully read and follow all charging instructions.
- To prevent unintentional starting, ensure the vacuum is powered off before picking up or carrying the vacuum. **DO NOT** carry the appliance with your finger on the power switch.
- For IA3000 Series, use only the XDCKIA3000UK charging dock (One battery can be charged) or DK25A-220100H-B or GQ30B-225100-AB charger.
- Keep the battery away from all metal objects such as paper clips, coins, keys, nails, or screws. Shorting the battery terminals increases the risk of fire or burns.
- Under abusive conditions, liquid may be ejected from the battery. Avoid contact with this liquid, as it may cause irritation or burns. If contact occurs, flush with water. If liquid contacts eyes, seek medical help.
- Battery should not be stored at temperatures below 3°C (37.4°F) or above 40°C (104°F) to maintain long-term battery life.
- DO NOT** charge battery at temperatures below 5°C (40°F) or above 40°C (104°F). Charging improperly or at temperatures outside of the specified range may damage the battery and increase the risk of fire.
- Store the appliance indoors.
- DO NOT** expose the battery to fire or temperatures above 130°C (265°F) as it may explode.
- Use appliances only with specifically designated battery packs. Use of any other battery packs may create a risk of injury and fire.
- Disconnect the battery pack from the appliance before making any adjustments, changing accessories, or storing appliance. Such preventive safety measures reduce the risk of starting the appliance accidentally.
- Always ensure that the rechargeable battery is removed from the appliance before inserting into the battery charging sleeve.
- For IA3000 Series, use only Shark battery pack XIABTR540EU (18V 3750mAh 67.5wh)

### ODOUR (IA3000 SERIES ONLY)

- Observe the following when interacting with the Anti-Odour Technology cartridge:
  - DO NOT** attempt to disassemble Anti-Odour Technology cartridge.
  - Avoid direct contact with the fragrance pod in the cartridge.
  - DO NOT** directly inhale from the Anti-Odour Technology cartridge.
  - Keep away from children and pets.
  - Keep away from heat, sparks, and open flame.
  - DO NOT** place in direct sunlight.

### FRAGRANCE CARTRIDGE FIRST AID

- Observe the following when interacting with the Anti-Odour Technology cartridge:
  - Avoid contact with fabrics and finished surfaces.
  - Eye contact: Remove contact lenses if present. Rinse continuously with water for several minutes.
  - Skin contact: Wash hands thoroughly after handling. If irritation or rash develops, seek medical advice/attention.
  - Inhalation: Move person to fresh air if they are experiencing any respiratory symptoms. If symptoms persist, seek medical advice/attention.
  - Ingestion: **DO NOT** induce vomiting. Seek medical advice/attention.



ADJUSTING THE ANTI-ODOUR TECHNOLOGY INTENSITY

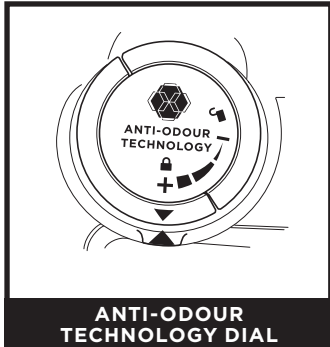

Flip up the dial handle and rotate the odour dial to adjust odour neutraliser technology intensity or to unlock the dial for cartridge access.

**Insertion/Removal:** Rotate the odour dial to align the teal arrows. Remove the dial to access the odour cartridge for removal or replacement.

**Low:** Rotate the dial toward the Low position to decrease the intensity to the lowest level when the vacuum is in use.

**High:** Rotate the dial toward the High position for the highest intensity level when the vacuum is in use. This position is the recommended setting for optimal performance.

ANTI-ODOUR TECHNOLOGY TIPS (IA3000 SERIES)

**The Anti-Odour Technology Dial Must be Installed for Vacuum to Function Properly**

- Remove anti-odour cartridge from dial if you don't want the benefits of the Anti-Odour Technology.

**Maintenance Required**

- Clean all filters as recommended under Cleaning Filters.
- Empty the dust cup before storing your vacuum.
- Replace the cartridge as recommended under Odour Cartridge Replacement.
- Visit [sharkclean.co.uk](http://sharkclean.co.uk) to learn more and purchase replacements.

**Fragrance Strength Over Time**

- The intensity of the Anti-Odour Technology's fragrance may diminish over time. It may also have no noticeable fragrance at all. This is natural and does not indicate the technology isn't working. Follow replacement instructions to ensure continued performance.

**NOTES:** • The odour dial needs to be installed for the vacuum to function properly, with or without the odour cartridge.

ODOUR CARTRIDGE REPLACEMENT

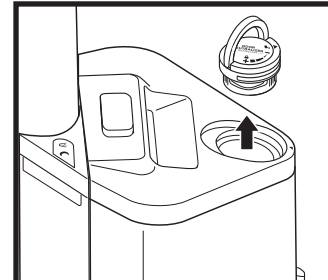

1. REMOVE ODOUR DIAL FROM THE AUTO-EMPTY DOCK

Flip up the handle and rotate the dial clockwise until the two arrows are aligned. Pull the handle to remove the dial from the auto-empty dock.

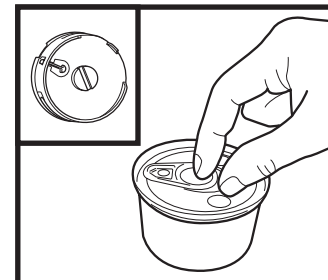

3. REMOVE NEW CARTRIDGE FROM CAN

Remove the new Anti-Odour cartridge from the can. To maintain the life of the cartridge, keep it in the can until you are ready to install it.

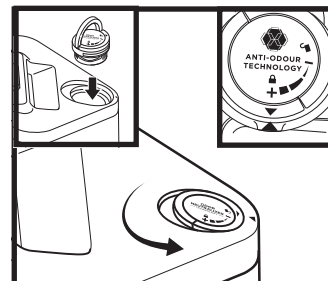

5. INSTALL DIAL IN THE AUTO-EMPTY DOCK

Align the teal arrow on the dial cover with the arrow on the auto-empty dock, then reinsert the dial into the auto-empty dock. Rotate the dial counterclockwise until it clicks into an intensity setting to engage. Rotate further to change the intensity setting.

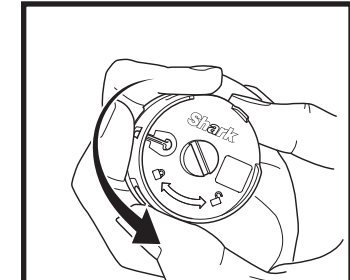

2. REMOVE OLD ODOUR CARTRIDGE

Rotate the cartridge counterclockwise in the dial housing and pull out the cartridge to remove it.

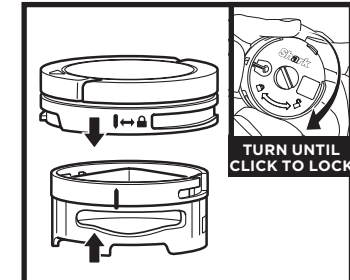

4. INSTALL NEW CARTRIDGE IN DIAL

Align the yellow arrow on the side of the cartridge with the yellow arrow on the side of the dial cover, then insert the cartridge into the dial. Rotate the cartridge clockwise to lock it in place.



6. USED CARTRIDGE DISPOSAL

Dispose of the old cartridge by dropping it into the bin.

**NOTE:** Odour cartridges should be replaced every 6 months for optimal odour neutraliser technology performance.

## CHARGING YOUR LI-ION BATTERY

Prior to first use, charge the battery completely. A full charge takes approximately 6 hours.

### RUNTIMES PER FULLY CHARGED BATTERY

With a full charge, the unit will have up to a 60-minute runtime. Visit [support.sharkclean.co.uk](http://support.sharkclean.co.uk) online for more information.

### LED BATTERY POWER AND CHARGING INDICATORS

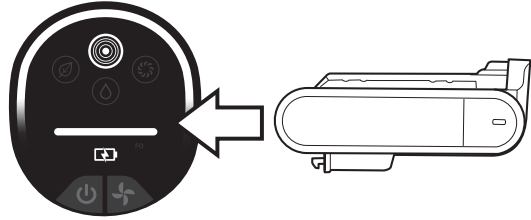

**NOTE:** Battery consumption will vary depending on the mode being used:

ECO - Maximum Runtime, saves battery power

AUTO - Optimises suction and power for maximum cleaning

BOOST - Maximises suction. Uses the most battery power

### Charging

 LED on the battery pack will pulse yellow when reaching 0-75% charge.

 LED on the battery pack will pulse green from 75% - 100% charge.

 White LED the battery pack is fully charged.

**NOTE:** Full charge takes approximately 6 hours.

#### Additional Notes

1. LEDs turn off once the battery is fully charged.
2. Unit will not power on when charger is connected.

### BATTERY CHARGING INFORMATION



### RECYCLING THE LI-ION BATTERY

When the Shark Li-ion battery needs to be replaced, dispose of it or recycle it in accordance with local ordinances or regulations. In some areas, it is illegal to place spent lithium-ion batteries in the standard rubbish bin. Return spent batteries to an authorised recycling centre or to the retailer for recycling. Contact your local recycling centre for information on where to drop off the spent battery.

**NOTE:** The Shark battery, like all lithium-ion batteries, will naturally decrease in capacity over time from the 100% capacity of a new battery.

## CHARGING YOUR LI-ION BATTERY

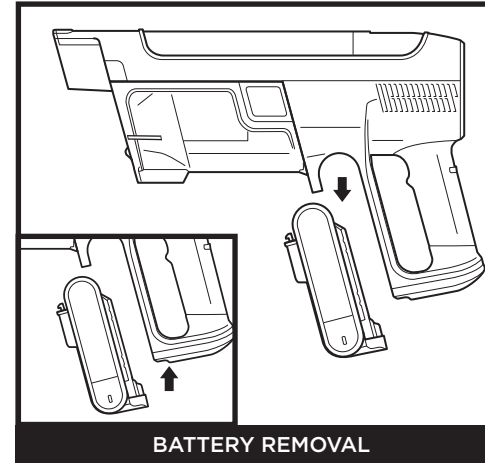

To remove the battery from the vacuum, press the release button on the battery and slide out of the handle compartment. To reinstall, slide the Battery back into the compartment until it clicks into place.

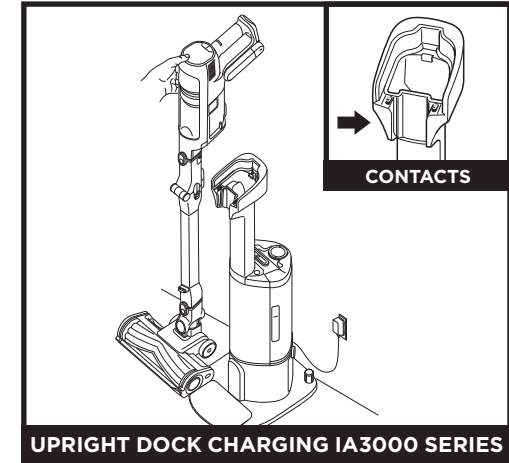

Charge the unit by placing it on the dock. Make sure the contacts on the hand vac are aligned with the contacts on the charging post. When charging is complete and you need to use the unit again, lift it off the dock.

**NOTE:** When the unit is docked properly, the charging lights on the battery will blink, indicating that charging has begun.

**NOTE:** The main unit comes with a partial charge. For maximum runtime, charge fully before first use (approximately 6 hours). Leaving the unit plugged in will not damage battery life.

CONTROLS AND CLEANING MODES

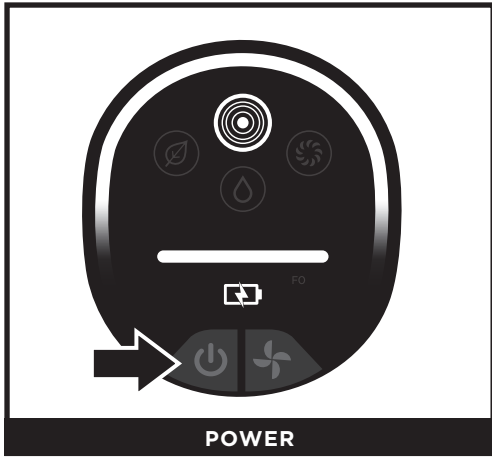

POWER

Press the  $\text{\textcircled{I}}$  button on the UI Screen to turn on power. To turn off power, press the button again.

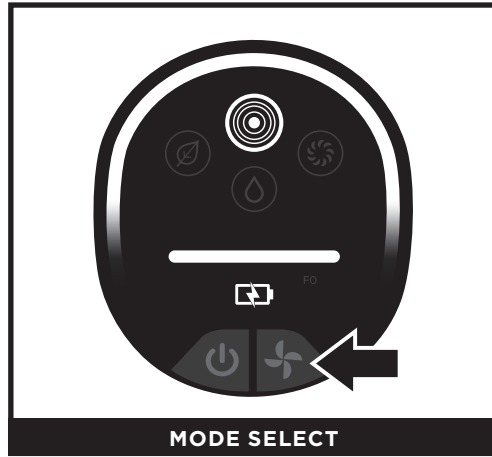

MODE SELECT

To toggle between ECO, DETECT, and BOOST modes, press the mode selection button. In DETECT mode, Detect Technology automatically adjusts vacuum and nozzle power to maximise cleaning performance and optimise runtime.

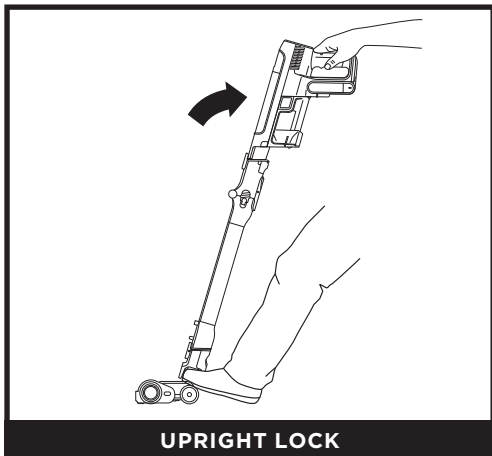

UPRIGHT LOCK

To begin cleaning with the floor nozzle, disengage the lock by stepping on the nozzle and tilting the hand vac down.

**NOTE:** For - Best Cleaning on ASTM and IEC Cleaning Tests, Use **Boost** Mode.

DETECT TECHNOLOGY EXPLAINED

**NOTE:** Detect Technology is ONLY operational in Detect Mode and is activated automatically when the unit is in use.

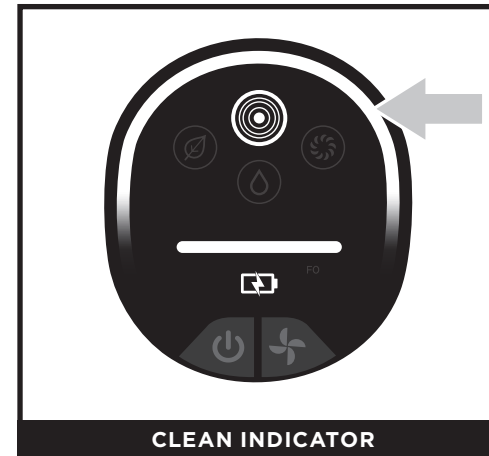

CLEAN INDICATOR

When the LED indicator ring is white, this means no heavy debris is detected and suction power is normal. When the vacuum senses heavy debris, the light will turn deep purple, and suction will increase for more cleaning power. When the indicator light turns light purple, debris is being removed—continue cleaning until the indicator turns white again.

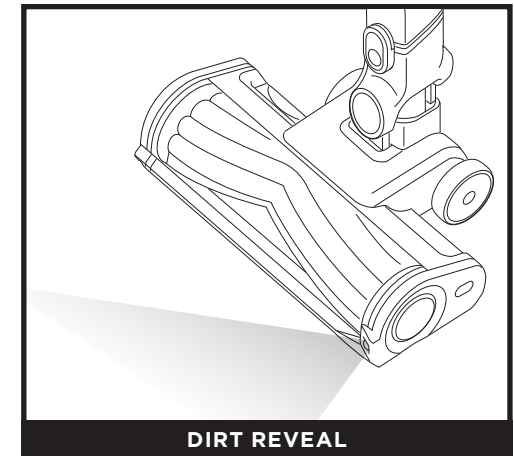

DIRT REVEAL

On hard floors ONLY, the Dirt Reveal light illuminates the cleaning path so you can more easily spot dirt and debris.

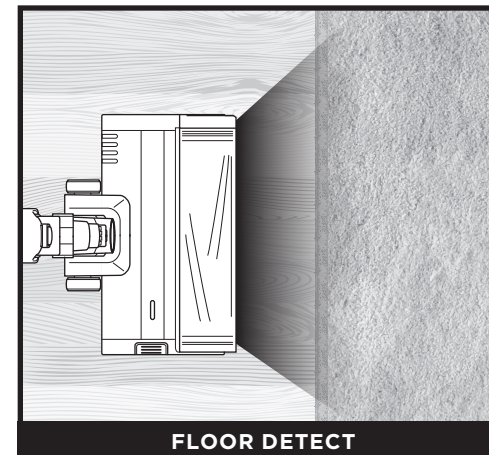

FLOOR DETECT

Brushroll and vacuum responds to surface changes and automatically adjusts to optimise your clean.

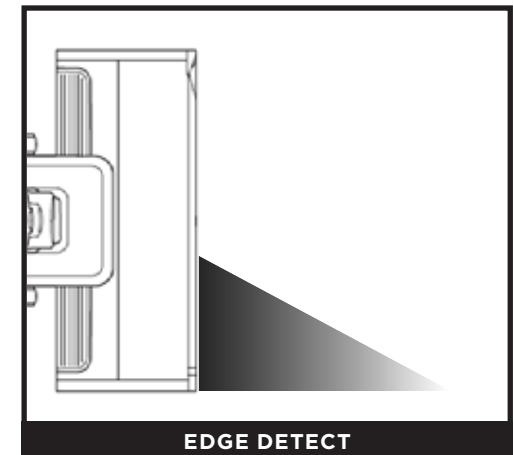

EDGE DETECT

Vacuum floor nozzle detects edges and corners and maximises suction and power to remove stubborn dirt.

**FLEXOLOGY**

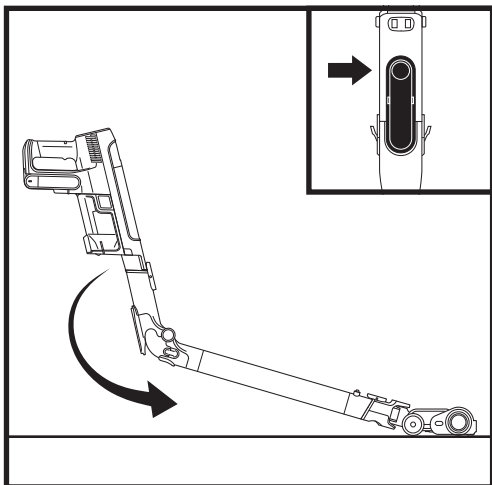

Flexology allows you to flex the wand to reach under furniture and clean debris in hard-to-reach areas.

To engage the Flexology feature, press the unlock button on the back of your Flex Wand.

For straight wand cleaning, return the wand to its original angle. You will hear a click when it is securely back in place.

**STORAGE**

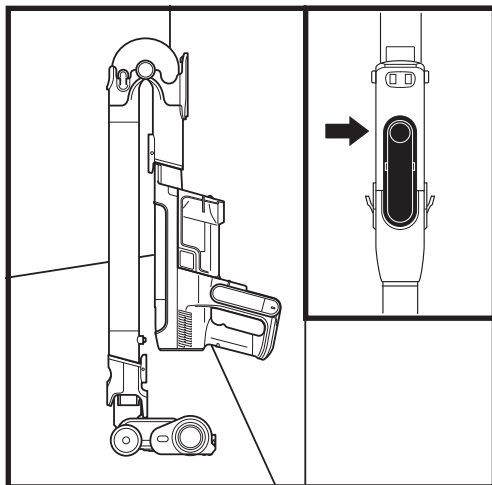

To put the vacuum into storage mode, press the Flexology wand unlock button while folding the handheld vacuum forward until it is resting against the wand.

To release vacuum from storage mode, unfold the vacuum until the wand straightens and clicks securely back in place.

**ABOVE-FLOOR CLEANING**

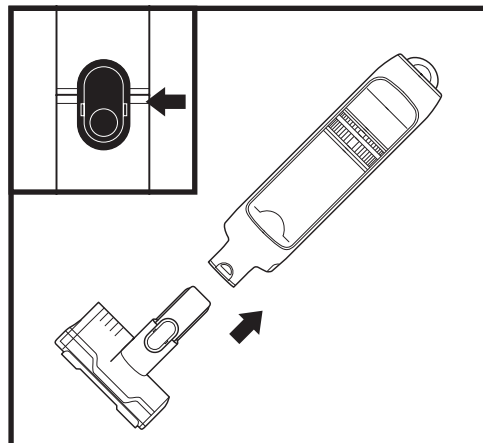

**ABOVE-FLOOR WITH HAND VACUUM**

Detach the hand vacuum to clean above-floor areas. Press the front latch release button on the hand vac where it meets the wand, then lift off the hand vacuum. To attach an accessory to the hand vacuum, slide it into the opening in the nozzle. To remove, press the front latch release button on the hand vac where it meets the wand, and slide out the accessory.

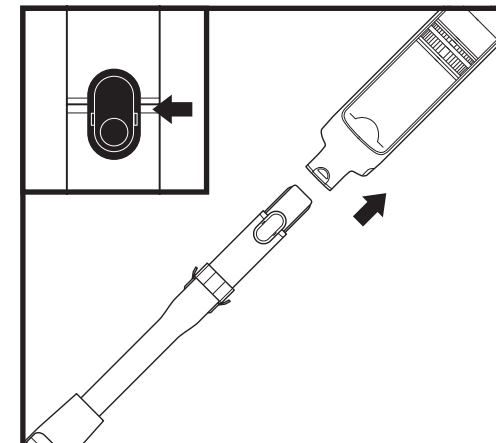

**ABOVE-FLOOR WITH WAND**

To detach the floor nozzle from the wand, step on the nozzle while pressing the nozzle release button at the bottom of the wand. Lift the wand to remove it. To reattach the wand, align it over the neck of the floor nozzle, then slide it on until it clicks into place.

USING THE AUTO-EMPTY DOCK (IA3000 SERIES)

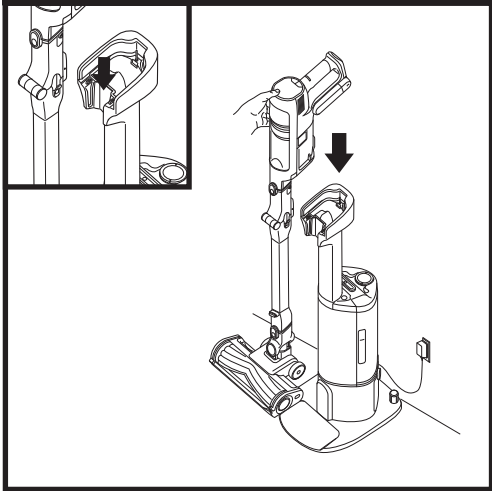

Place the vacuum on the dock in a downward motion. Once properly attached, the auto evacuation process will begin. The evacuation cycle will last for 15 seconds.

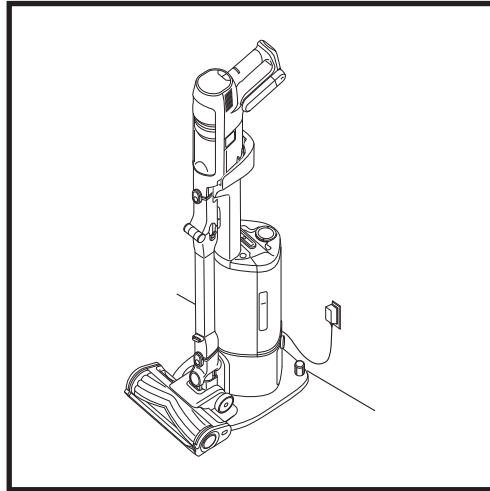

Once evacuation is complete, the vacuum will continue charging until it is removed from the dock.

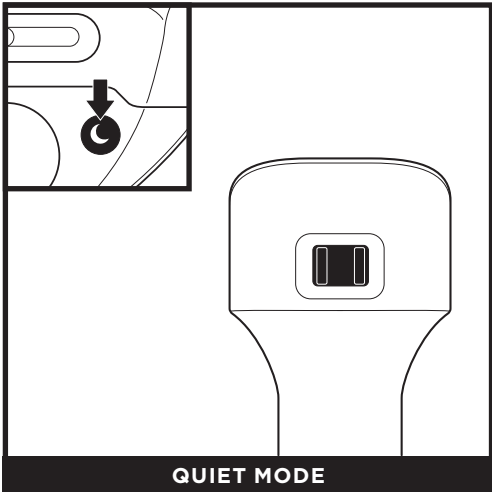

QUIET MODE

Use Quiet Mode to dock and charge the vacuum without automatic evacuation. To activate Quiet mode, slide the switch on top of the charging post.

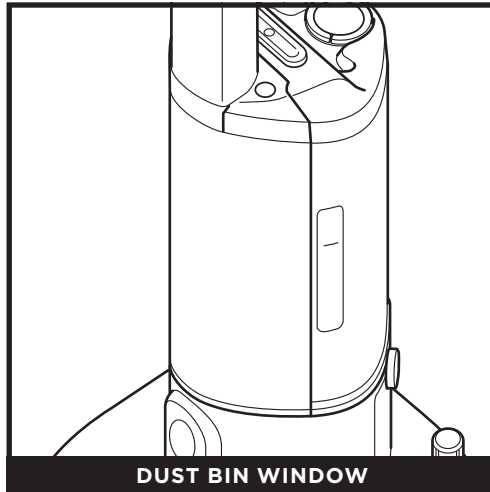

DUST BIN WINDOW

The Dust Bin Window will show how full the dust bin is. When the window is full, remove the dust bin and empty it.

**Note:** Do not remove the vacuum while the evacuation cycle is taking place.

EMPTYING THE DOCK DUST BIN (IA3000 SERIES)

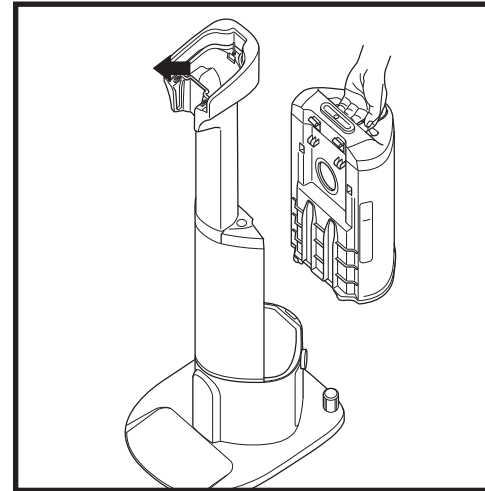

The dock dust bin holds up to 45 days' worth of dust and debris. Empty the dock dust bin when the dust bin window shows debris at the fill line. To remove the bin, lift it out by the handle.

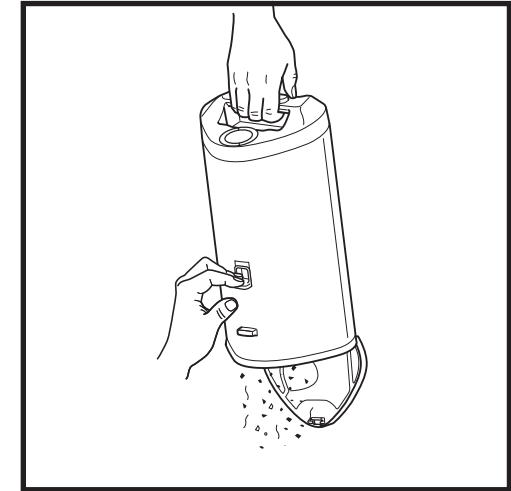

To empty the bin, hold it over the rubbish bin and press the release button on the side. The bottom will open to release the debris.

CLEANING THE VACUUM FILTERS

**NOTE:** For best results, **clean your filters at least once a month** and replace the filters regularly. To clean filters, clear loose debris and rinse with cold water **ONLY** to prevent damage from cleaning chemicals. Allow all filters to dry fully before reinstalling to prevent liquid from being drawn into electrical parts. Maintaining your Filters will ensure successful cleaning and Auto-Empty evacuation (IA3000 series only).

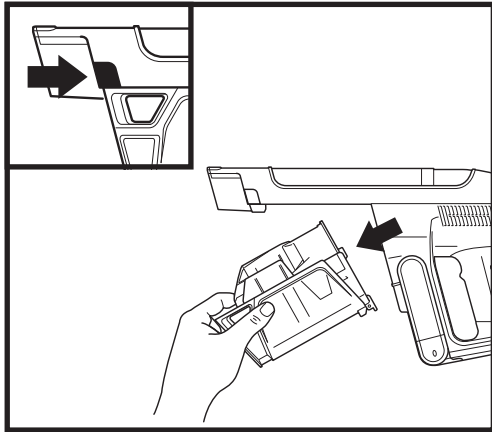

1. To access the dust cup on your IA3000 hand vacuum, engage the dust cup removal button and pull downward to disengage from the hand vacuum.

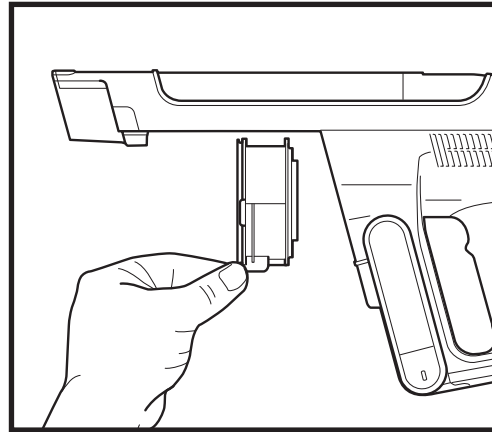

2. Pull the release tab to remove the Post Motor filter for the vacuum.  
3. After cleaning, slide the filter back into the vacuum.

CLEANING THE AUTO-EMPTY DOCK FILTER

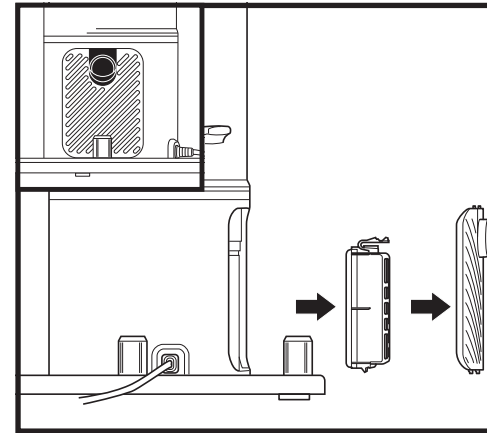

To access the filter in the dock, Press the button at the bottom of the door, then tilt the door and lift it off. Remove the filter from the dock. After the filter has been cleaned, reinstall it by reinserting back into the dock and replacing the filter door.

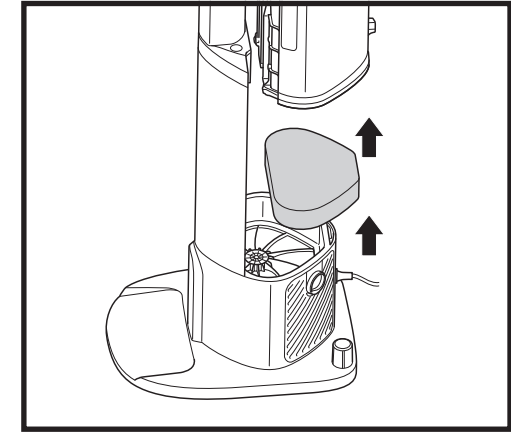

Filter, remove the dust bin. Before removing the Exhaust Foam Filter, remove any fine debris from the surface using the hand vacuum. Lift the Exhaust Foam Filter out of the dock to clean and then reinstall.

NOZZLE MAINTENANCE

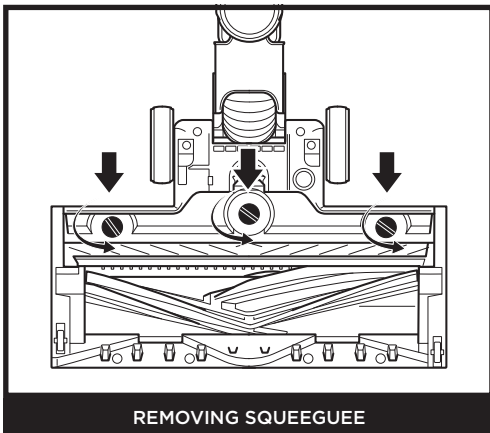

REMOVING SQUEEGEE

1. Turn off the vacuum.
2. Press the nozzle release button to detach the nozzle from the wand.
3. Remove rear squeegee by turning screws.
4. Clear out any blockages and debris from behind the squeegee.
5. Reinstall squeegee and turn screws until they lock into place.

CLEANING THE SENSORS

Make sure to clean the Detect sensors regularly, as hair and other debris may build up and obstruct them. If the sensors are partially obstructed, Clean Sense Detect mode will not function as expected.

To clean the sensors:

1. Turn off power and remove the floor nozzle.
2. Locate the Dirt Detect Sensor in the nozzle of the hand vac (Fig. 1), the Edge Detect sensor on the side of the nozzle (Fig. 2), and the Floor Detect Sensor (Fig 3) on the bottom of the nozzle.
3. Gently wipe the sensors with a microfibre cloth and remove all hair and debris.
4. Reattach the floor nozzle to the rest of the unit and turn on power. Verify that the unit is functioning normally.

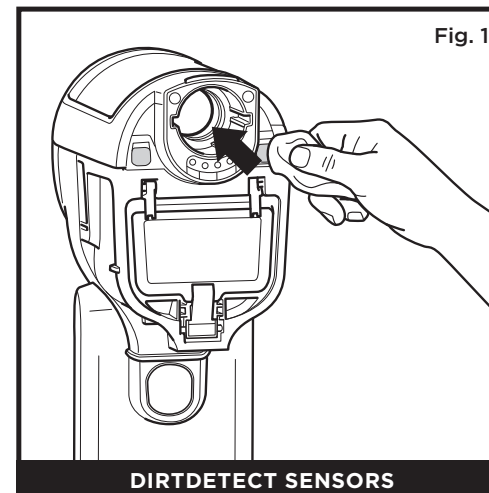

DIRTDETECT SENSORS

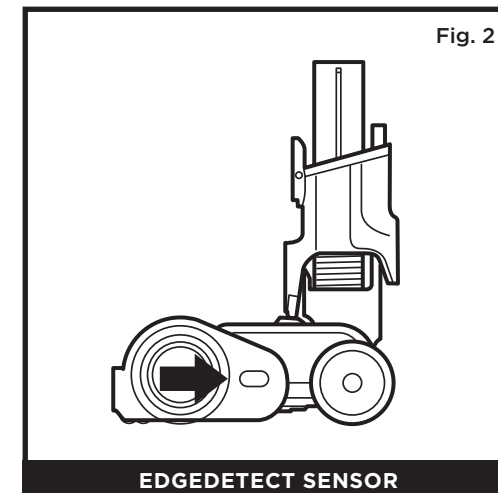

EDGEDETECT SENSOR

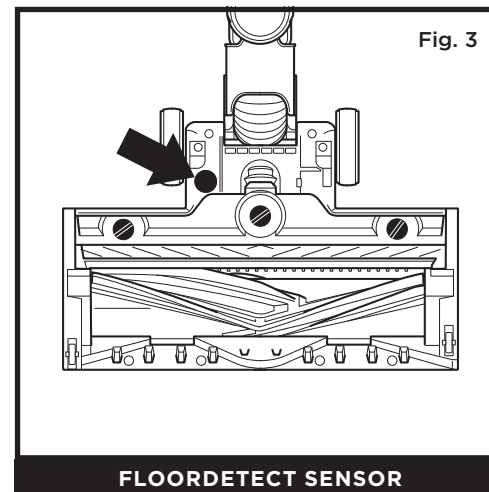

FLOORDETECT SENSOR

CHECKING FOR BLOCKAGES IN THE VACUUM

If you run over a hard or sharp object or notice a noise change while vacuuming, check for blockages or objects caught in the brushroll.

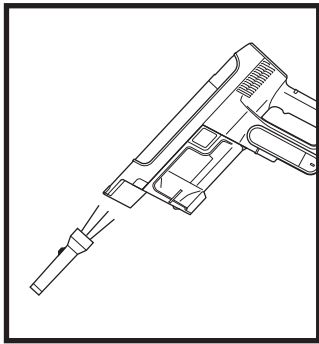

Checking for Blockages in the Hand Vacuum:

1. Turn off the vacuum.
2. Remove the hand vacuum from the wand.
3. Check all intake openings to the dust cup and remove any debris or blockages.

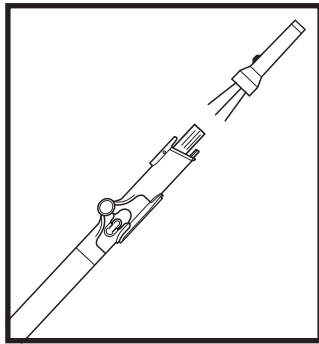

Checking for Blockages in the Wand:

1. Turn off the vacuum.
2. Detach the hand vacuum and floor nozzle from the wand.
3. Check both ends of the wand for blockages and debris.
4. Clear away any debris or blockages.

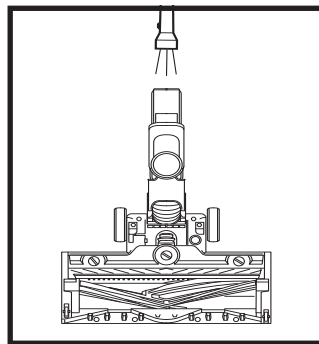

Checking for Blockages in the Floor Nozzle:

1. Turn off the vacuum.
2. Detach the wand from the floor nozzle.
3. Remove the soleplate from the bottom of the nozzle.
4. Clear any blockages and release any debris from the brushroll and floor nozzle.
5. Replace the soleplate, ensuring everything is lined up and in place.

CHECKING FOR BLOCKAGES IN THE AUTO-EMPTY DOCK (IA3000 SERIES)

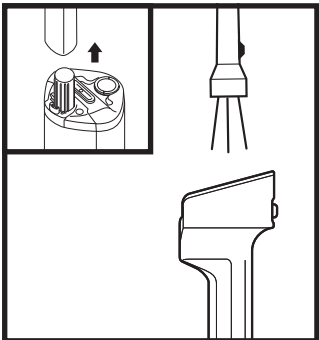

Checking for Blockages in the Charging Post:

1. Unplug the dock.
2. Remove the vacuum from the dock.
3. Press the latch on the back of the charging post and lift the post away from the dock.
4. Check the end of the charging post and top of the dock for any debris or blockages.

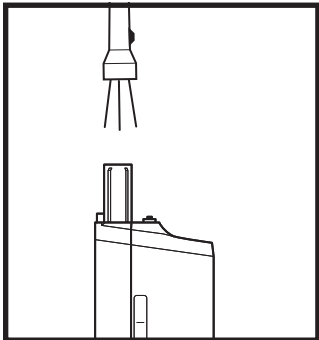

Checking for Blockages in the Dock:

1. Unplug the dock.
2. Remove the vacuum from the dock.
3. Remove the dust bin from the dock.
4. Check the exit for any debris or blockages.

TROUBLESHOOTING

- ⚠ **WARNING:** To reduce the risk of shock and unintended operation, turn off power and remove the battery before servicing.
- ⚠ **WARNING:** If the supply cord is damaged, it must be replaced by the manufacturer, its service agent or similarly qualified persons in order to avoid a hazard.

Vacuum is not picking up debris. No suction or light suction. Third indicator light on hand vacuum is solid yellow.

(Refer to Checking for Blockages section for more information.)

1. Dust cup may be full; empty dust cup.
2. Check floor nozzle for blockages; clear blockages if required.
3. Remove any string, carpet fibers, or hair that may be wrapped around the brushroll.
4. Check connection between hand vacuum and wand for blockages; clear blockages if required.
5. Check filters to see if they need cleaning. Follow instructions for rinsing and completely air-drying the filters before reinstalling them.

Vacuum lifts area rugs.

1. Make sure you are not engaging Boost mode. Take care when vacuuming area rugs or rugs with delicately sewn edges.
2. Turn off the unit to disengage from the carpet, then restart.

The brushroll in the floor nozzle doesn't spin.

1. Immediately turn off the vacuum. Remove any blockages before turning the vacuum back on. Make sure the hand vacuum is tilted back far enough for the brushroll to engage while in use.
2. If the floor nozzle has headlights and they are not illuminated, there is a connection issue between the hand vacuum, wand, and nozzle. Try detaching the parts, then reconnecting them.

Vacuum turns off on its own.

There are several possible reasons for the vacuum turning off on its own, including blockages, battery issues, and overheating. If vacuum turns off on its own, perform the following steps:

1. Turn on the vacuum and check the battery indicator lights on the hand vacuum. If recharging is needed, make sure vacuum power is off placing it on the charging dock.
2. Empty dust cup and clean filters (See the Cleaning the Dust Cup and Filter section).
3. Check wand, accessories, and inlet openings and remove any blockages.
4. Allow unit and battery to cool for at least 45 minutes, until they return to room temperature.
5. Press the On/Off switch to restart the vacuum.

Malfunction	Component	Error Icons phase 1	Error Icons phase 2	LED Icons
Nozzle Clog or Stalling	Nozzle	LED Ring is Flashing Purple	↔ No LEDs	
Motor Failure during start up	Hand Vacuum	Eco, Detect, Boost LEDs on	↔ Eco, Detect LEDs on	
Over Temperature Protection	Hand Vacuum	Eco, Detect, Boost LEDs on	↔ Boost, Detect LEDs on	
Over Current protection	Hand Vacuum	Eco, Detect, Boost LEDs on	↔ No LEDs	
Short Protection	Hand Vacuum	Eco, Detect LEDs on	↔ No LEDs	
Overspeed Protection	Hand Vacuum	Detect LEDs on	↔ Eco, Boost LEDs on	
Communication failure	Hand Vacuum	Eco, Detect LEDs on	↔ Detect, Boost LEDs on	
Over Temperature Protection	Nozzle	Eco, Boost LEDs	↔ No LEDs	
Short Protection	Nozzle	Detect, Boost LEDs on	↔ No LEDs	
Debris Detection Failure	Hand Vacuum	FO LEDs & LED Ring on	↔ No LEDs	
Edge Detect Error	Nozzle	FO LED on, LED Ring on & Headlight LEDs	↔ No LEDs	

**NOTE:** If vacuum still does not operate properly, contact Customer Service on +44 (0)800 862 0453

- A** Crevice Tool
- B** Duster Crevice Tool
- C** Flexible Crevice Tool
- D** Anti-Allergen Brush
- E** Multi-Surface Tool
- F** Motorised Hand Tool
- G** Wide Upholstery Tool
- H** Car Detail Kit
- I** Replacement Battery
- J** Hand Vacuum Pre-Motor Filter
- K** Hand Vacuum Post-Motor Anti-Allergen Filter
- L** Auto-Empty Dock Post-Motor Filter
- M** Auto-Empty Exhaust Foam Filter
- N** Battery Charging Sleeve

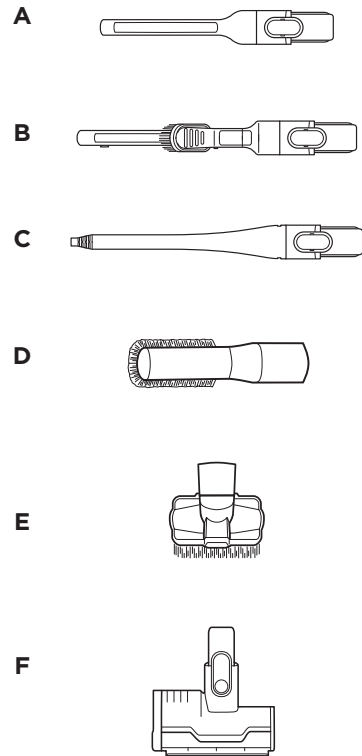
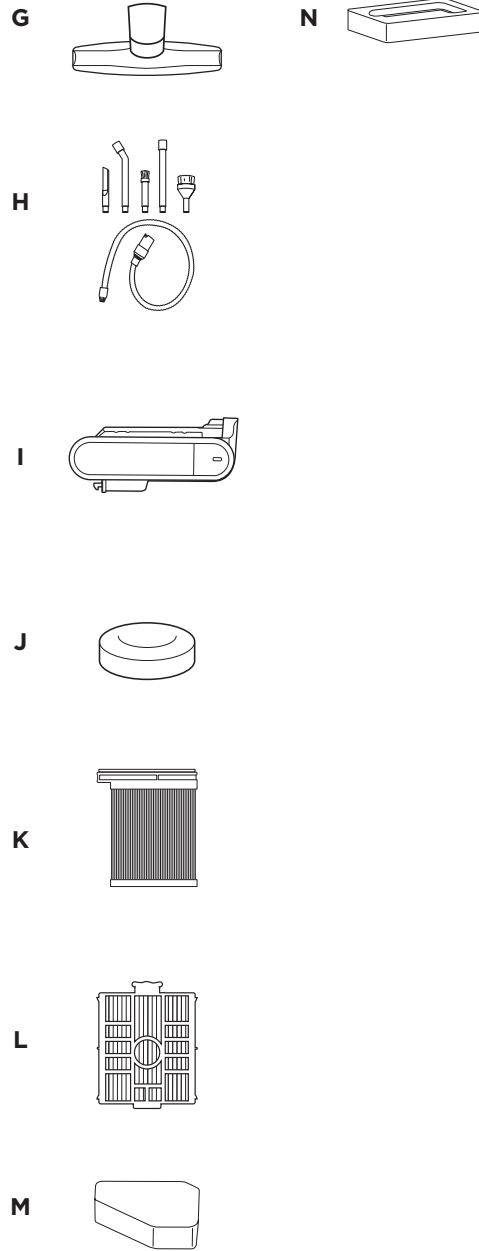

**NOTE:** Not all accessories come with all units. Please see the Quick Start Guide on the packaging box for your unit's configuration. To order additional accessories, visit [sharkclean.co.uk](http://sharkclean.co.uk).

## MANUFACTURER'S GUARANTEE

### The Shark Guarantee

When a consumer buys a product in the UK, they get the benefit of legal rights relating to the quality of the product (your "legal rights"). You can enforce your legal rights against your retailer, including Shark if you bought your appliance from [sharkclean.co.uk](http://sharkclean.co.uk). However, at Shark we are so confident about the quality of our products that we give the owner an additional, free parts and labour manufacturer's guarantee of up to 5 years (2 years for batteries).

The guarantee it comes with is an important consideration - and reflects how much confidence the manufacturer has in its product and manufacturing quality.

The manufacturer's guarantee does not affect your legal rights.

### How long are new Shark machines guaranteed for?

Our manufacturer's guarantee lasts for one year from the date of purchase as standard, or for five years (two years for batteries) if you register your purchase with us within 28 days.

### How do I register my Shark guarantee?

If you have purchased your Shark appliance directly from [sharkclean.co.uk](http://sharkclean.co.uk) your guarantee is registered automatically. If you bought it from anywhere else in the UK, you can register your guarantee online within 28 days of purchase.

- To register online, please visit [sharkclean.co.uk/register-guarantee](http://sharkclean.co.uk/register-guarantee) or scan the QR code in your instruction booklet.

- Keep a note of the date you purchased the machine.

### IMPORTANT:

- Keep your receipt if you bought your Shark appliance from anywhere except [sharkclean.co.uk](http://sharkclean.co.uk). You will need it to claim under your guarantee.

- The free Shark guarantee only applies in the UK.

### What are the benefits of registering my free Shark guarantee?

When you register your guarantee, you will get an extra four years of cover (extra one year for batteries). We'll also have your details to hand if we ever need to get in touch. If you further agree to receive communications from us, you can also receive tips and advice on how to get the best out of your Shark appliance and hear the latest news about new Shark technology and launches.

### What is covered by the free Shark guarantee?

Repair or replacement (at Shark's discretion) of your Shark machine, including all parts and labour.

### What is not covered by the free Shark guarantee?

- Normal wear and tear.
- Accidental damage or faults caused by negligent use or care, misuse, neglect, careless operation or handling of the Shark appliance which is not in accordance with the Shark Operating Manual supplied with your machine.
- Damage caused by use of the Shark appliance for anything other than normal domestic household purposes.
- Damage caused by use of parts not assembled or installed in accordance with the operating instructions.
- Damage caused by use of parts and accessories which are not Shark Genuine Components
- Faulty installation (except where installed by Shark).
- Repairs or alterations carried out by parties other than Shark or its agents.

### How can I claim under the free Shark guarantee?

Contact our customer service helpline on 0800 862 0453. For service hours please visit our website under 'Contact Us'. It's free to call, and you'll be put straight through to a Shark representative. You'll also find online support at [support.sharkclean.co.uk](http://support.sharkclean.co.uk). The Shark representative will go through some troubleshooting with you, and if we conclude that the item has failed, we will send you a replacement part or a returns label to send the defective item back to us free of charge. When you have delivered the defective product to us, we will send you a replacement.

Please remember that the item will need to be boxed when you return it to us. It can be any suitable box, it does not have to be the original packaging.

### Where can I buy genuine Shark spares and accessories?

Shark spares and accessories are developed by the same engineers who developed your Shark appliance. You'll find a full range of Shark spares, replacement parts and accessories for all Shark machines at [sharkclean.co.uk](http://sharkclean.co.uk). Please remember that damage caused by the use of non-Shark spares may not be covered under your guarantee.



## ODOUR NEUTRALISER SPECIFICATIONS

1. Product Name: Odour Neutraliser Cartridge
2. Manufacturer: Shark Ninja 89 A Street, Needham, MA 02494
3. Weight: 17.4g / 0.61oz
4. Ingredients: Solid SM composite polymer C17 + fragrance SE 272235



**SharkNinja Europe Ltd,  
1st/2nd Floor Building 3150,  
Thorpe Park, Century Way,  
Leeds, England, LS15 8ZB UK  
+44 (0)800 862 0453  
www.sharkclean.co.uk**

**SharkNinja Germany GmbH,  
Rotfeder-Ring 9,  
60327 Frankfurt am Main,  
Germany**

Illustrations may differ from actual product. We are constantly striving to improve our products; therefore the specifications contained herein are subject to change without notice.

© 2025 SharkNinja Operating LLC. FLOOR DETECT and SHARK are registered trademarks of SharkNinja Operating LLC in the United Kingdom.

IA3000UK\_Series\_CondensedIB\_MP\_Mv3  
PRINTED IN CHINA

 @sharkhomeuk

 @sharkhomeuk

 @sharkhomeuk